

*** IMPORTANT INFORMATION ***

BEFORE YOU START

Installation should be performed by a competent person only. This product could be dangerous if incorrectly installed.

Check the pack to ensure all of the components are included.

When you are ready to start, make sure that you have all of the correct tools to hand, have plenty of space, and that the area for building is clean and dry.

Do not rush! Read these instructions first and run through the sequence before you begin. Assembly should be carried out in the steps shown in the following diagrams, constructing one unit at a time and keeping fittings together to avoid loss. Lay large panels on the floor using the packaging for protection. Do not overtighten screws, as this may damage the cabinet.

If any items are missing, or problems arise with fitting, please call the **Manufacturers' Helpline on 01769 575500**.

To clean - use mild soap and water only.

Do not use abrasive cleaners.

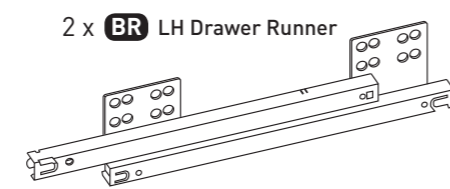

2 x **BR** LH Drawer Runner

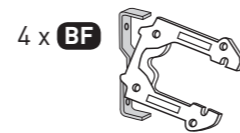

4 x **BF**

HARDWARE:



2 x **BJ**



4 x **BW**

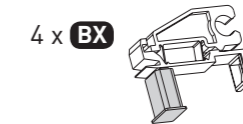

4 x **BX**

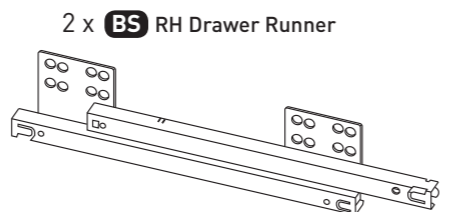

2 x **BS** RH Drawer Runner



4 x **BG**



2 x **BK**

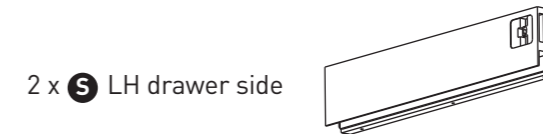

2 x **S** LH drawer side



16 x **BE** Euro Screw



2 x **BN**



2 x **T** RH drawer side

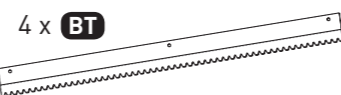

4 x **BT**



36 x **D** 15mm



4 x **BP**

2 x **U** Metal Drawer Back



2 x **BV**

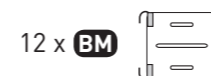

12 x **BM**



6 x **BL**



Please use scissors to open the bag of fittings and then empty the contents into a bowl, so that they do not get lost!

MINIMUM TOOLS REQUIRED:



CROSS HEAD SCREWDRIVER

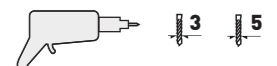

DRILL & DRILL BITS (3mm & 5mm)



TAPE MEASURE

PANELS:

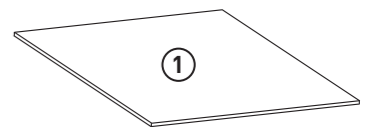

2 x **1** Drawer Base

STEP 1:

Before fitting drawer runners to base end panels, check that you have a 'pair' of runners for right and left hand operation. Pull top metal runner fully towards you to establish 'handing'.

The highlighted hole positions must be used, as detailed in Fig 1, (RH panel shown).

Fix the RH runner **BS** to the RH end panel using 4 x screws **BE**, and then repeat for the LH runner **BR** on the LH end panel.

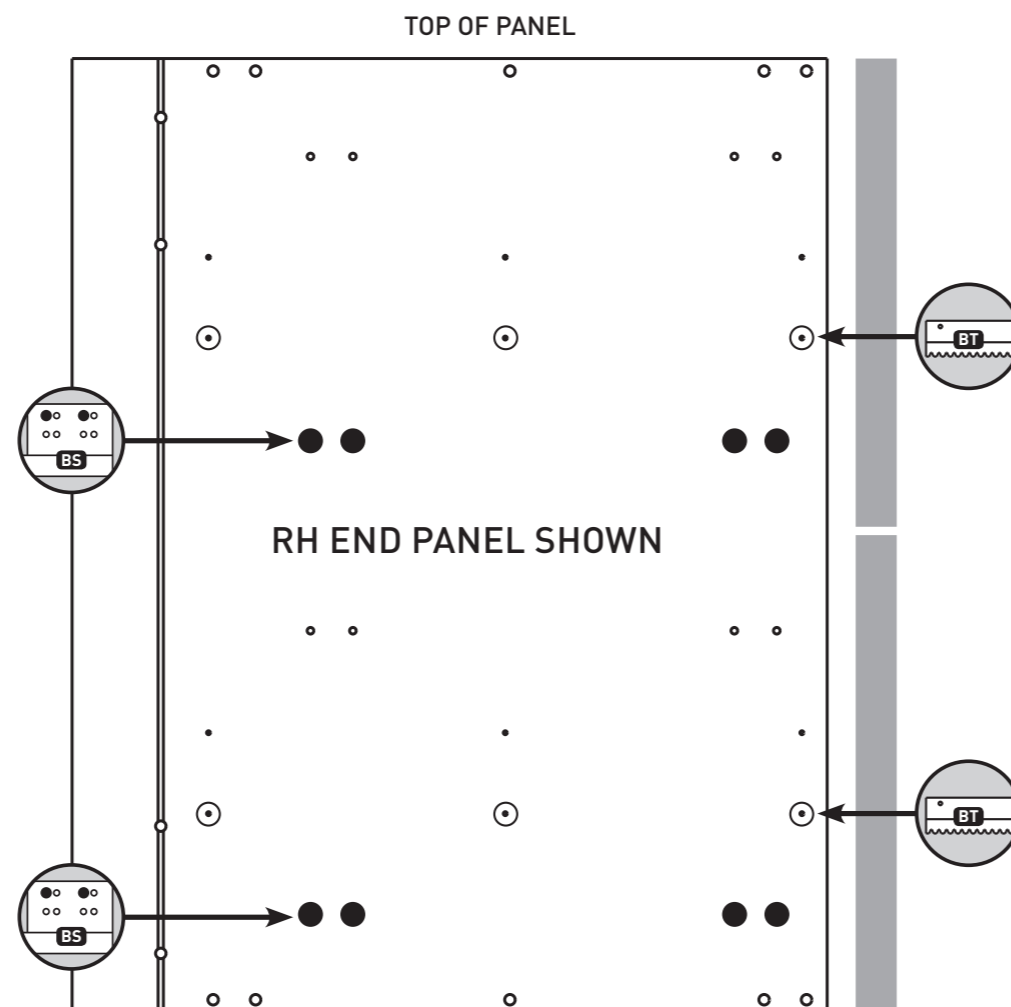

FIGURE. 1

STEP 2:

The toothed rails **BT** should be fitted, as shown, using 3 x **D** screws each, before fitting the drawers, in order to stabilise the drawer itself, during operation.

The cogs fitted to the back of the drawers should then run smoothly along these rails.

STEP 3:

Clip drawer sides **S** and **T** to Metal drawer back **U**.

Turn Drawer upside down and slide Base Panel **1** into position.

Secure with 2 x **D** screws per side.

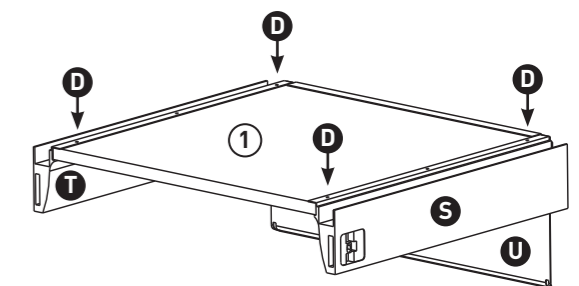

NOTE: When building the curved pan drawers, the drawer base **1** should not be secured in place until after the drawer front has been secured. This should ensure a minimum gap between the drawer base and the drawer front.

STEP 4:

Turn drawer upside down and ensure both white plastic forks are set to the factory default position as shown below.

Reset the forks if they have moved to the opposite position (this will require firm pressure).

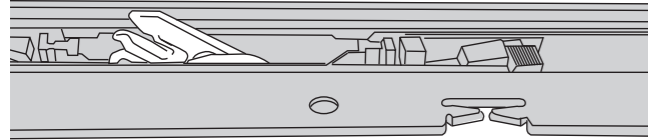

Turn the drawer the correct way up. Fully extend the drawer runners. Sit drawer sides on top of the extended drawer runners. Push drawer into cabinet until it 'clicks' into position.

NOTE: It will be necessary to remove the drawer to fix the components in **STEP 8**, and then re-fit once complete. Pressure at the back of the runner may be required, in this instance, in order to 'click' the drawer into position.

STEP 5:

Some ranges are pre-marked with different positions. If necessary mark and drill four holes **8mm deep** at **3mm diameter** in reverse side of drawer front.

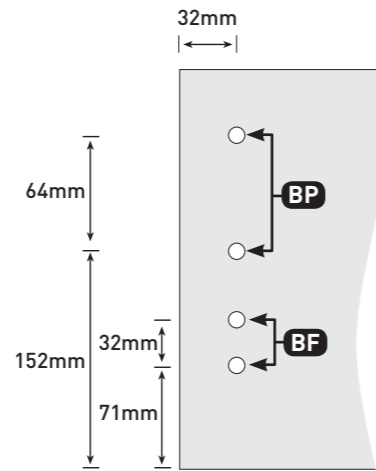

NOTE: Depending on the fascia range chosen you may have some unused pre-drilled holes on the reverse of the drawer front.

STEP 6:

Twist the plastic part of **BF** anticlockwise to reveal the holes (if the plastic and metal parts have become separated, simply join them back together).

Position **BF** on the reverse side of the drawer front and secure using screws **D**. Twist the plastic part of **BF** clockwise to lock into position.

Identify both left and right hand drawer extensions **BJ** and **BK**.

Remove plastic drawer front securing plates **BP** from front ends of drawer side extensions by holding 'extended pull tab' and pulling downwards to withdraw.

Now fit **BP** above **BF**, (keeping 'pull tabs' at the bottom) using 2 x screws **D** each, through the top and bottom holes only.

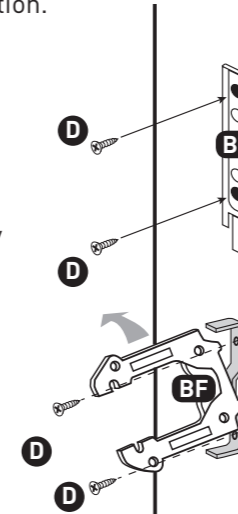

STEP 7:

Push drawer front connectors into white plastic part of drawer box sides until it locks into position.

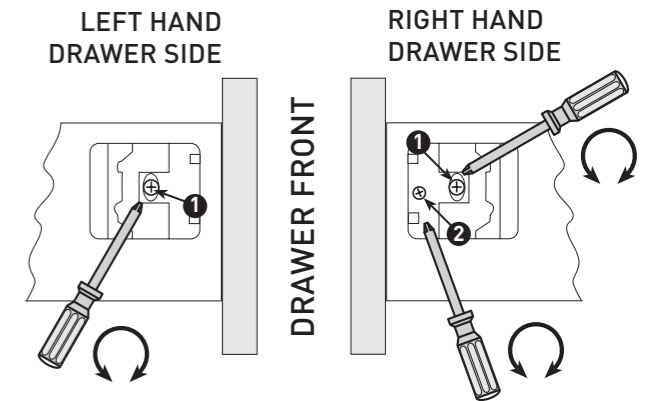

For **Vertical adjustment**, loosen screws **1** adjust Drawer front to desired position, re-tighten screws **1**.

For **Horizontal adjustment**, turn screw **2** clockwise or anticlockwise for required positioning.

NOTE: Screw **2** is only present in the RH drawer side.

STEP 8:

Note: The fitting of parts **BJ**, **BK**, **BL**, **BM**, **BN**, **BV**, **BW** and **BX** should be completed only once the drawer front has been secured to the drawer sides.

Place the drawer down on the front face, and insert the stabilising clips **BX**, at the back of each drawer side, (there is a small snap-on piece (shaded), which should be removed, before fitting) as shown in Fig 2.

Now identify both left and right hand drawer extensions **BJ** and **BK**, and push into place as shown in Fig 3, ensuring that the stabilising clips are held firmly in place. The cog ends **BW** should now be fitted to each end of the metal stabilising bar **BV**. This can now be fitted to the two stabilising clips **BX**, pushing into place to locate.

Place the drawer back onto its base. Identify Front Rail **BN**, (which has spring loaded ends), and fit this in between parts **BJ** and **BK**, at the front, as shown in Fig 4. The spring loaded ends will engage with the small recessed slots.

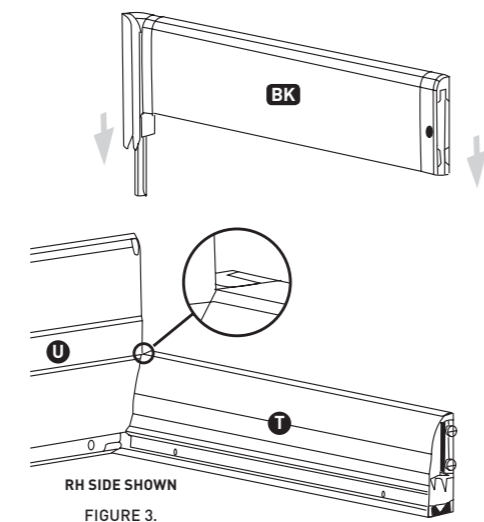
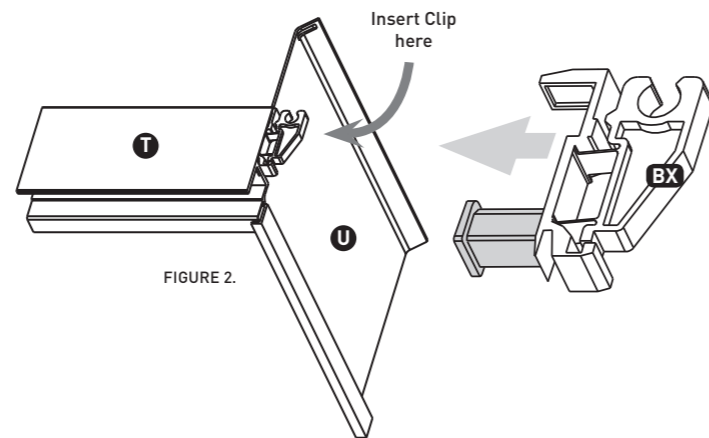

Identify the centre divider **BL**. Ease the locating lugs at the back into the slots in the Metal Drawer Back **U**, and then clip the curved moulding at the front over the Front Rail **BN**, pushing downwards to engage (see Fig 5).

Place the adjustable dividers **BM**, with the large curved moulding at the top, in the required positions within the drawer, and secure to the centre divider **BL**, by pushing firmly downwards (see Fig 6).

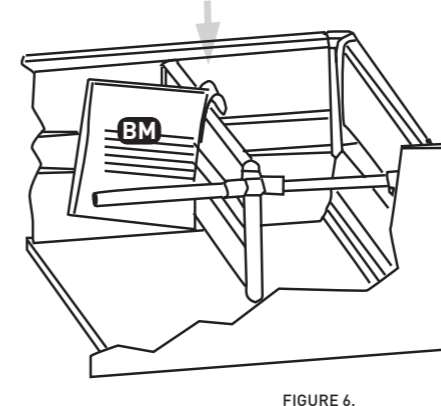
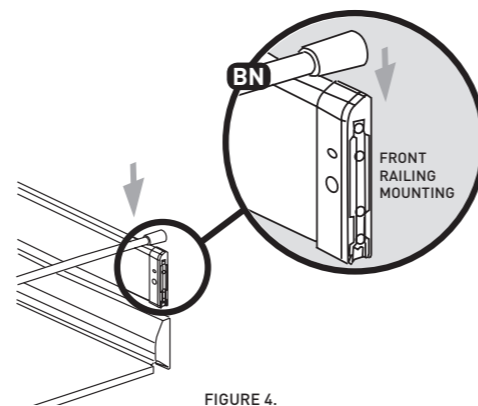
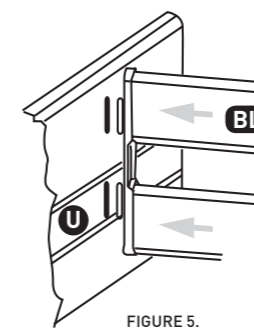

STEP 9:

Once any adjustments have been made, the drawer front must be locked into place by fitting the locking plates **BG**, as shown.

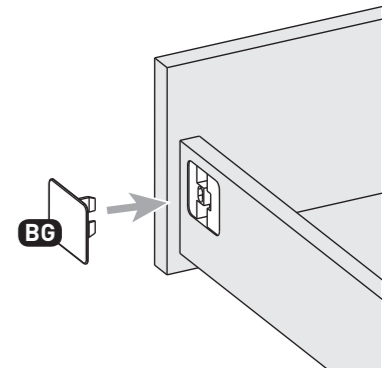

STEP 10:

Fast assembly system for quick fixing or removal.

To remove drawers push up both black/grey tabs together (located underneath both sides of drawer near the front) while pulling out from carcass.

